

Arvand®

OFFICE AND
AMPHITHEATER
CHAIRS
2021-22



WWW.ARVAND-CHAIR.COM

Office & Amphitheater Chairs

60 years ago we started from a modest beginning, designing and manufacturing metal products for offices , hospitals as well as various kinds of swivel chairs for conference halls. Even from the very beginning we manufactured products which conformed to international standards. All of the parts except Gas springs were manufactured locally using the highest quality raw material. Putting the safety and health of users before every thing else, designing our products according to the latest ergonomic principles.

During the past 20 years our hard work and attention to safety of customers paid off and we are now transformed into an industrial group, with craftsmen capable of manufacturing almost all required parts equal to the highest international standards within the group, allowing us to provide customers with 3 year guarantee.

Today Arvand high standards of workmanship has not only put us among the leading chair manufacturers in the country but early start - 60 years ago - places us among the pioneers of this field in Iran.

We hope to have an ever-increasing effect on the promotion of this industry inside the country.

Contents

59	series	4	2320 series	34
57	series	6	2340 series	35
60	series	8	3912 series	36
55	series	10	3910 series	37
44	series	12	4110 series	38
33	series	14	4010 series	42
56	series	16	4013 series	43
30	series	17	Barcelona series	44
36	series	18	Le Corbusier series	48
18	series	19	Florence series	50
20	series	20	Eames series	54
34	series	21	1420 series	56
17	series	22	1740 series	57
29	series	24	70 series	58
58	series	26	15 series	59
54	series	27	3010 series	60
37	series	28	2710 series	62
10	series	30	2810 series	63
38	series	31	some projects	64
21	series	32	dimensions	72
23	series	33		



59 series

A pencil translates faithfully what has been imagined.

Another creativity of Arvand company for people who want to have the best design in their offices. A new design has new way of life, have relaxability at work and every thing together.

CODE: 5912



CODE: 5910



CODE: 5910



CODE: 5912



4

5



CODE: 5912



CODE: 5912



CODE: 5910



CODE: 5910

57 series

A different point of view; a different way of produce.

The Arvand corporation has created a completely new kind of mesh chair. The "57" Series uses the world's most advanced seating technology to create office chairs to meet the needs, especially for today's cutting-edge workspaces.

6

CODE: 5714



CODE: 5711



CODE: 5710



CODE: 5712



7

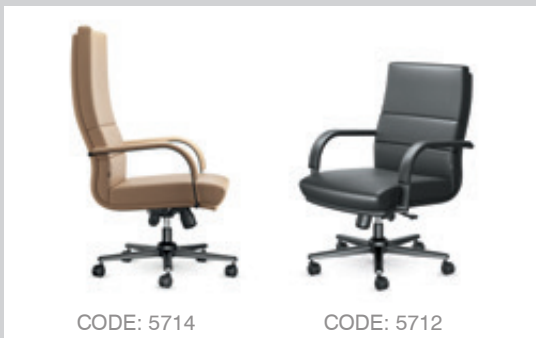

CODE: 5714

CODE: 5712

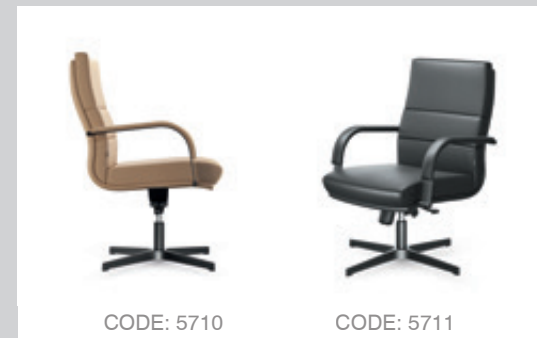

CODE: 5710

CODE: 5711

60 series

A new idea, is an amazing creativity in this time.

60series are a new design of our company. These models are blending with another ideas in the best smaples of famou's companies work at the world.

8



CODE: 6014



CODE: 6012

9



CODE: 6012



CODE: 6014

CODE: 6014

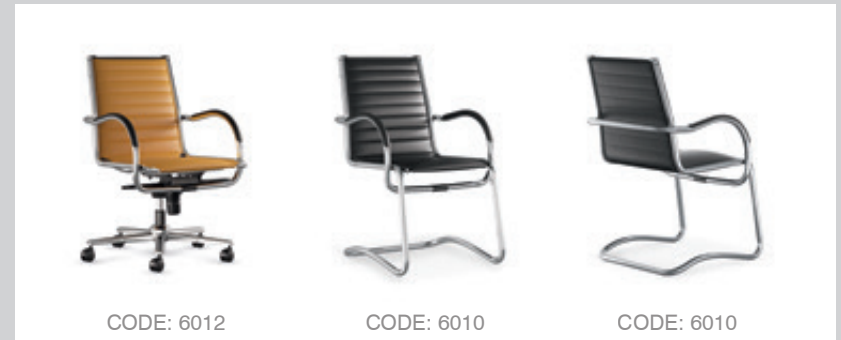

CODE: 6012

CODE: 6010

CODE: 6010

55 series

An elegance that leans towards removing what is superfluous.



Experience the pleasure of sitting in a chair of the most advanced ergonomic design. Complement and invigorate any office arrangement with a chair design of extra ordinary simplicity. Embellish your workspace with a choice of 6 mesh fabric colors. The Arvand corporation has created a completely new kind of mesh chair. The “55” Series uses the world’s most advanced seating technology to create office chairs to meet the needs, especially for today’s cutting-edge workspaces.



44 series

A different point of view; a different way of produce.

44series classic can be equipped with different types of mechanisms, according to the needs. in the top version, 44series features a dynamic knee tilt mechanism of new generation lockable in 5 positions and anti-panic system. the tilt tension can be adjusted by a practical side handle, according to the user`s weight.

12



13



44series Classic outer structure is in shiny and chromed aluminium with an elegant rear handle at the top of the back, to favour movements. The fixed cantilever arms match the structure and can be upholstered with a top in the same material as the armchair. Different types of upholstery, bases and casters offer the possibility to choose the most suitable version for your needs.



CODE: 3316

14



CODE: 3320

15



CODE: 3310H



CODE: 3314



CODE: 3310L



CODE: 3320



CODE: 3318

56 series

Creativity is not limited by time or way of thinking.

16



CODE: 5614



CODE: 5610



CODE: 5610

30 series

Designers constantly confront themselves with different aspects of creativity.

17



CODE: 3014



CODE: 3214



CODE: 3114

36 series An elegance that leans towards removing what is superfluous.

18



CODE: 3614

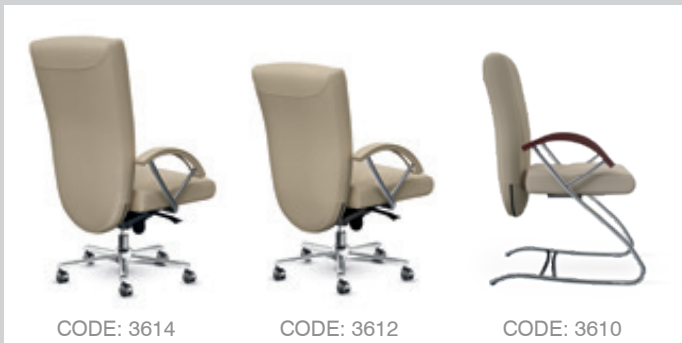

CODE: 3614

CODE: 3612

CODE: 3610

18 series A pencil translates faithfully what has been imagined.

19



CODE: 1814



CODE: 1814

CODE: 1914

CODE: 1910

20 series An idea, intuition is a flash.



CODE: 2014

20

34 series A creative use of all that scientific research has to offer.



CODE: 3414



CODE: 3414

21



CODE: 2014

CODE: 2016

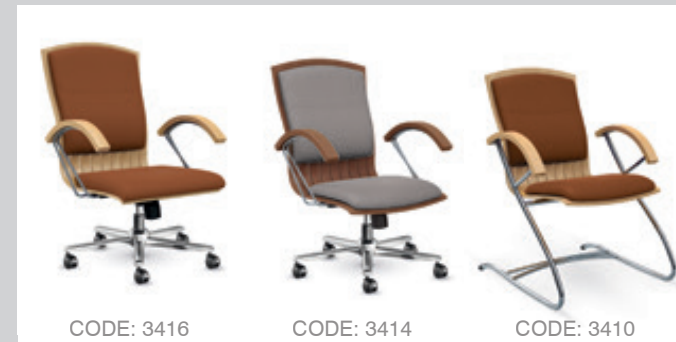

CODE: 3416

CODE: 3414

CODE: 3410

17 series A chair for sinking back and plunging into blissful comfort.

Single seater with character.

22



CODE: 1714

23



CODE: 1720-H

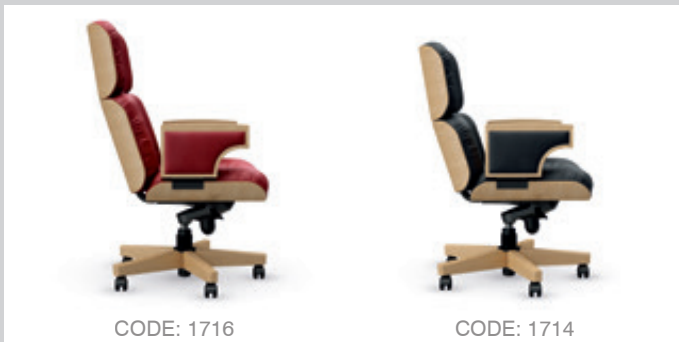

CODE: 1716

CODE: 1714



CODE: 1720-H

CODE: 1720-L

24



CODE: 2914

25



CODE: 2920-H



CODE: 2914

CODE: 2912



CODE: 2910-H

CODE: 2910-L

58 series

An elegance that leans towards removing what is superfluous.



54 series

There is a creativity that can be called artistic
this is art itself.

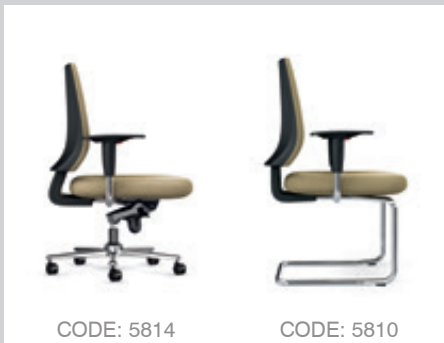

Fresh and progressive. Not loud, but gratifyingly different.

Beautifully and comfortable to see a match.

28



CODE: 3714

29



CODE: 3720

CODE: 3720

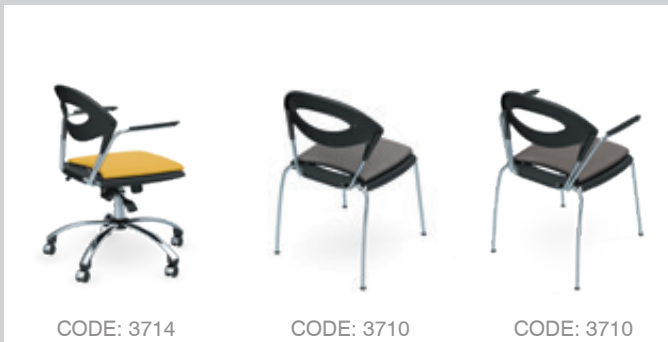

CODE: 3714

CODE: 3710

CODE: 3710



CODE: 3720

CODE: 3720

10 series An elegance that leans towards removing what is superfluous.

CODE: 1010



30

38 series An easy chair that is totally new.

CODE: 3810



CODE: 3814



31

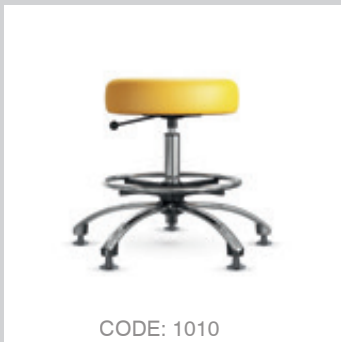

CODE: 1010



CODE: 3810S

CODE: 3810

21 series

An elegance that leans towards removing what is superfluous.

32



CODE: 2110

23 series

an example of rationality that made it a contemporary object.



CODE: 2310



CODE: 2310

33



2320 series

Forms of an apparent simplicity which hides a complex structure and meticulous research.

34



CODE: 2320

2340 series

an example of rationality that made it a contemporary object.



CODE: 2343

CODE: 2340

35

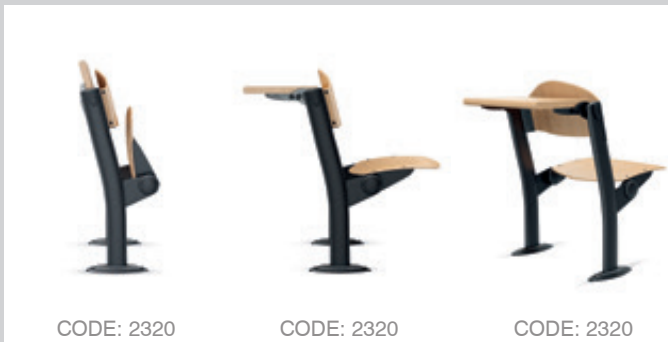

CODE: 2320

CODE: 2320

CODE: 2320



CODE: 2340

CODE: 2343

3912 series

This idea has produced a whole range of unconventional seating solutions.



CODE: 3912

36

3910 series

A modern evolution of the sofa.



CODE: 3910

37



CODE: 3912



CODE: 3910

Seating Group

This idea has produced a whole range of unconventional seating solutions.

38



CODE: 4210

Different moods in three sofas with Three coffee tables are provided you the best condition of designing.

CODE: 4310



39

CODE: 4110



CODE: 4110

CODE: 4110



CODE: 5210,5310

CODE: 5111

CODE: 5110

Seating Group



This idea has produced a whole range of unconventional seating solutions.

A group of modular pieces that allow to construct many different compositions depending.

Modular system is a masterstroke of creative upholstery.



220 cm
360 cm



210 cm
350 cm



The structure, padding, and covering are designed for maximum comfort.

The modular Pieces could set in different kinds of situations. This ability provides a complete group of furniture in every place.

Public Seating

A modern evolution of the Office sofa.

A line of armchairs and sofas which reinterpret the idea of the modern office.

The armchair with elegant geometrical lines as well as an ergonomic seat comfort.

Free from ostentation and excess.

CODE: 4010



42

CODE: 4013



43



CODE: 4012



CODE: 4010



CODE: 5010

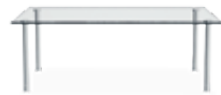

CODE: 5012



CODE: 4014



CODE: 4013



CODE: 5019

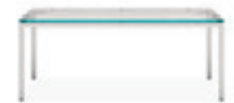

CODE: 5020

Barcelona series

A different point of view; a different way of perceiving, planning, producing and communicating our concepts.

Creativity is not limited by time or way of thinking.



CODE: 4019

CODE: 4017

44



CODE: 4020

45

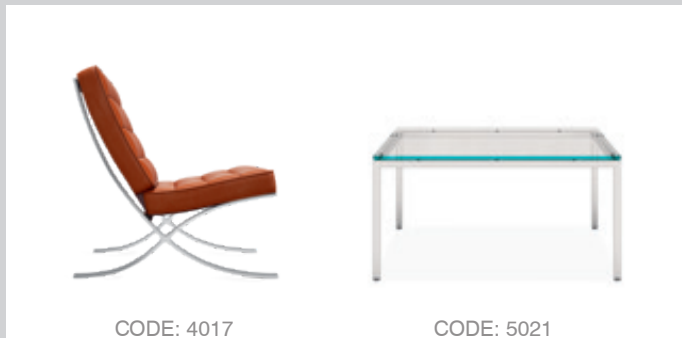

CODE: 4017

CODE: 5021

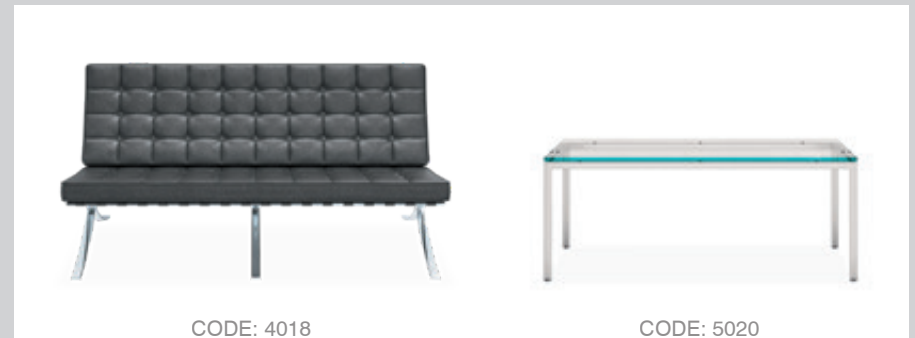

CODE: 4018

CODE: 5020

Arvand®
Since 1960

46



The Barcelona chair is a chair designed by Ludwig Mies van der Rohe and Lilly Reich. It was originally designed for the German Pavilion, that country's entry for the International Exposition of 1929.

Le Corbusier's Furniture is a classic furniture line created by Le Corbusier. The line was introduced in 1928 at the Salon d'Automne in Paris by Le Corbusier and his team of designers.

47



Now, we can produce these products with the best quality and it's our Honor in Iran.

Le Corbusier series

There is a creativity embedded in a firm's system its organization and sense of responsibility.

CODE: 4015

48



Creativity is not limited by time or way of thinking.



49



CODE: 4015

CODE: 5110



CODE: 4016

CODE: 5111

Florence series

A different point of view; a different way of perceiving, planning, producing and communicating our concepts.

50



CODE: 4030M

Creativity is not limited by time or way of thinking.

CODE: 4034M



51

CODE: 4032M



CODE: 4023M



CODE: 4021M



CODE: 4022M



CODE: 5019MW



CODE: 5020MG



CODE: 5021MS

Florence series

A modern evolution of the Office and home armchair.

52



CODE: 4030W

A line of armchairs and sofas which reinterpret the idea of the modern office.

CODE: 4034W



53

CODE: 4032W



CODE: 4023W

CODE: 4021W

CODE: 4022W



CODE: 5019WW

CODE: 5020WG

CODE: 5021WS

Eames series

A modern evolution of the chair.

The Chair takes timeless design and comfort to a new level.

54



55

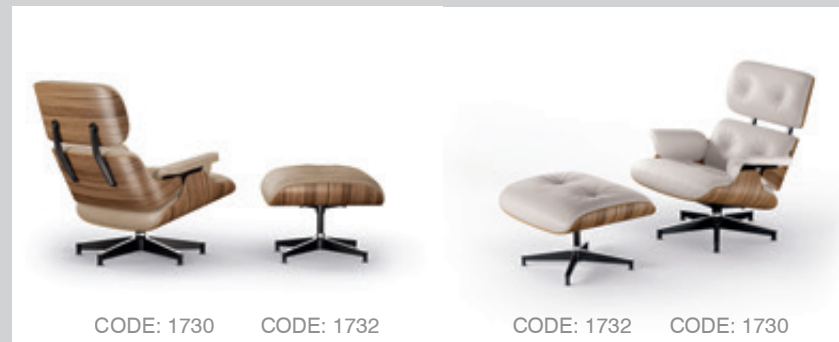
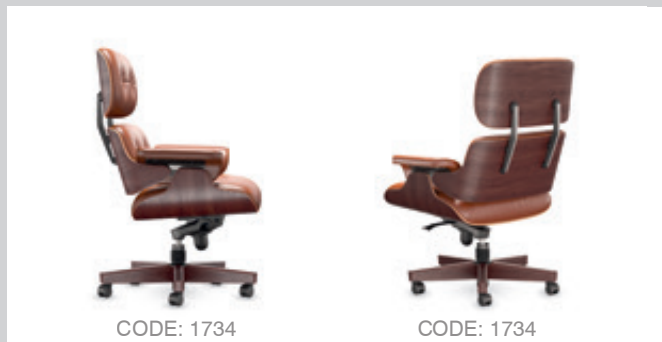

1420 series

This idea has produced a whole range of unconventional seating solutions.

56



CODE: 1420



CODE: 1420

1740 series

A modern evolution of the sofa.

A line of armchairs and sofas which reinterpret the idea of the modern office.

57



CODE: 1740

CODE: 1742

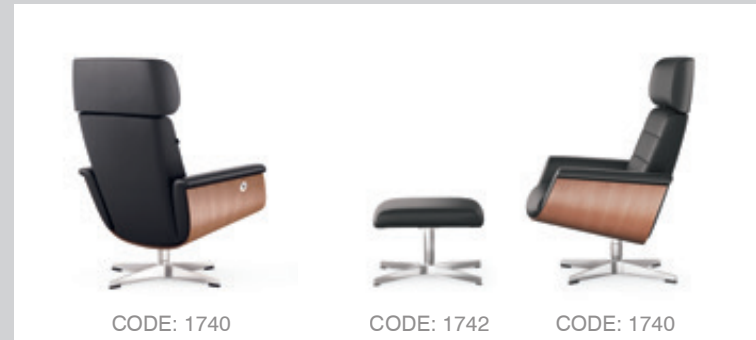

CODE: 1740

CODE: 1742

CODE: 1740

70 series

A new modern cinema chair with the comfortable seat.

CODE: 7020



58



15 series

The armchair with elegant geometrical lines as well as an ergonomic seat comfort.

CODE: 1520



CODE: 1520



59



CODE: 7011



CODE: 7010



CODE: 7014



CODE: 1520



CODE: 1520

3020 series

A chair for sinking back and plunging into blissful comfort.

CODE: 3020 D



60

A creative use of all that scientific research has to offer.

CODE: 3022 D



CODE: 3022



61



2710 series

Ultimate in comfort and Superb in its simplicity.

62

CODE: 2710 D



2810 series

The structure, the padding and the covering are designed for maximum comfort.

CODE: 2820 D



63



CODE: 2720

CODE: 2720

CODE: 2720



CODE: 2820

CODE: 2820

CODE: 2820



Islamic summit conference hall - Tehran

ساختمان اجلاس سران کشورهای اسلامی ۱۳۷۶



Summit building meeting hall - Tehran

سالن جلسات ساختمان اجلاس سران

Islamic summit conference hall - Tehran

سالن اجلاس سران کشورهای اسلامی ۱۳۹۲



Islamic summit conference hall - Tehran

سالن اجلاس سران کشورهای اسلامی ۱۳۹۲





Isfahan International amphitheater Center
سالن اصلی مرکز همایش های بین المللی اصفهان



Milad tower amphitheater hall - Tehran
سالن همایش های بین المللی برج میلاد تهران

Isfahan International amphitheater Center
سالن اصلی مرکز همایش های بین المللی اصفهان

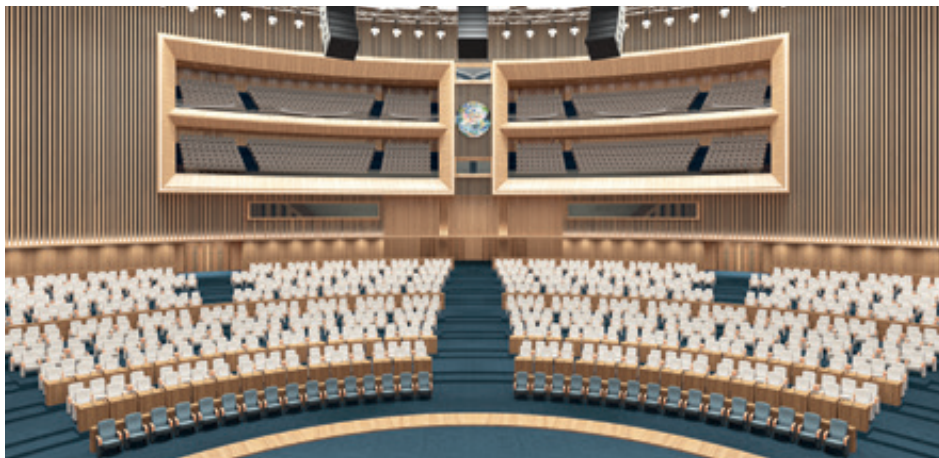

Milad tower amphitheater hall - Tehran
سالن همایش های بین المللی برج میلاد تهران





Pardis Technology Park

سالن همایش های پارک علم و فناوری پردیس



Pardis Technology Park

سالن همایش های پارک علم و فناوری پردیس

New Building of Parliament hall - Tehran

ساختمان مجلس شورای اسلامی



Golbang Conference Hall - Hafeziyeh

سالن همایش های بین المللی گلپایگ - مجموعه حافظیه (سعد آباد)





Imam Khomeini Cultural Center
فرهنگسرای امام خمینی (ره)



New Building of ministry of road and transportation
سالن همایش های وزارت راه و شهرسازی

National Library Main Hall
سالن همایش های کتابخانه ملی



Conference hall of Petrochemical Company
سالن همایش شرکت پتروشیمی - میدان شیخ بهایی تهران



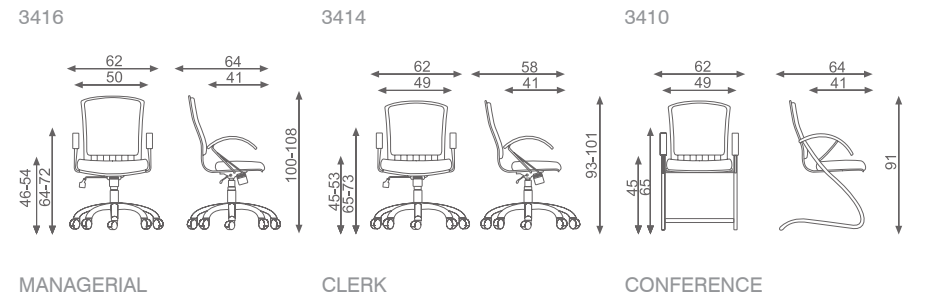
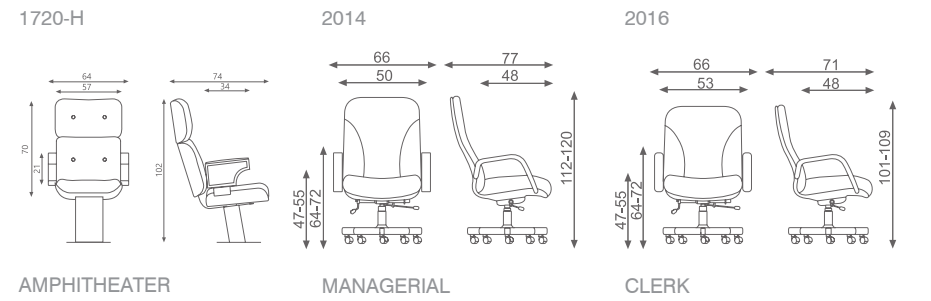
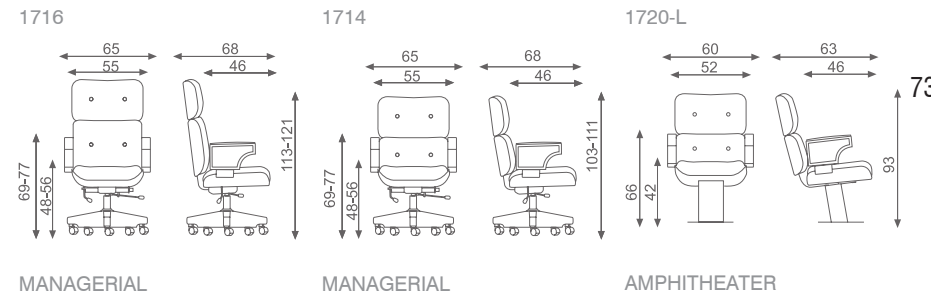
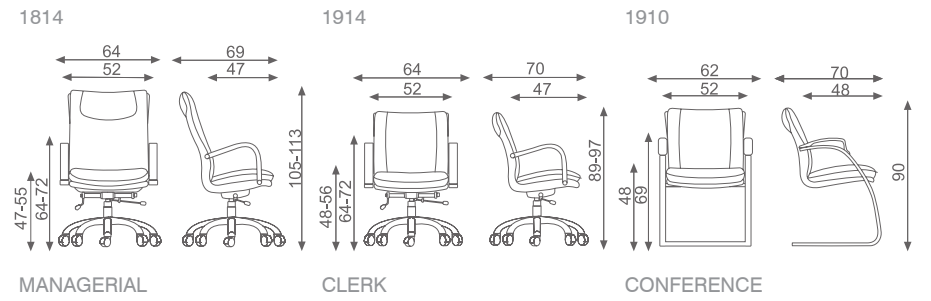
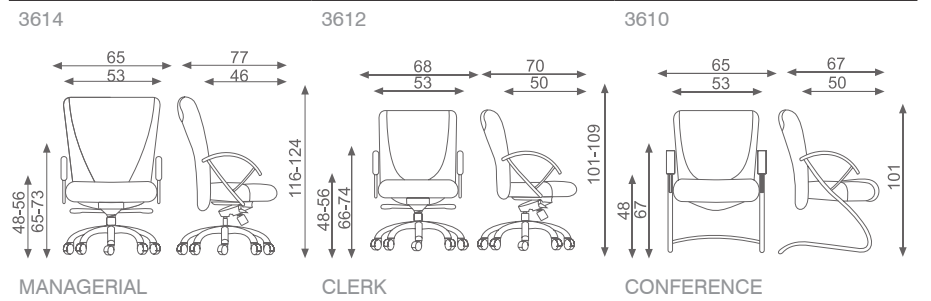
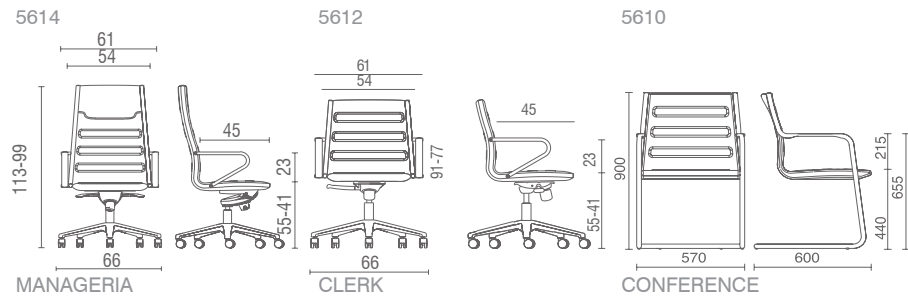
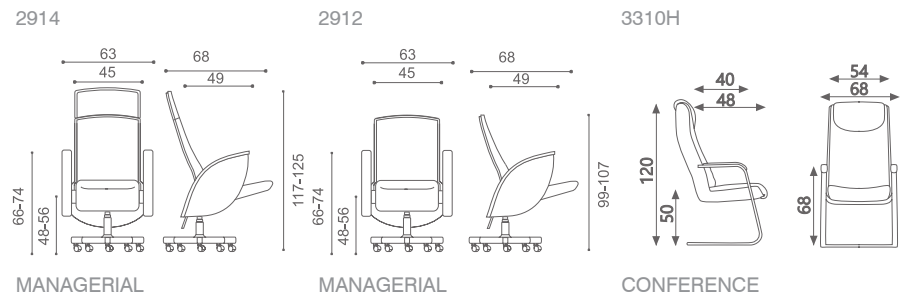
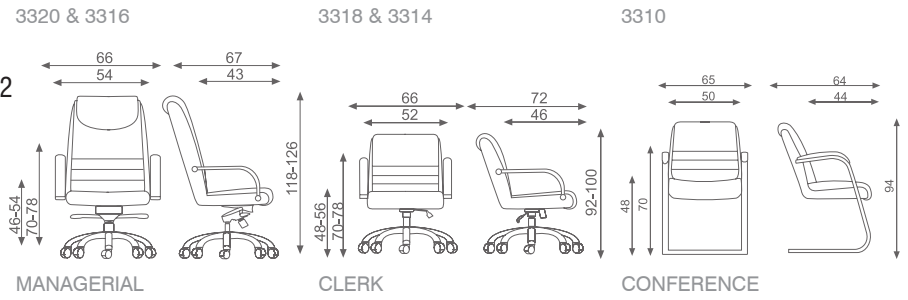
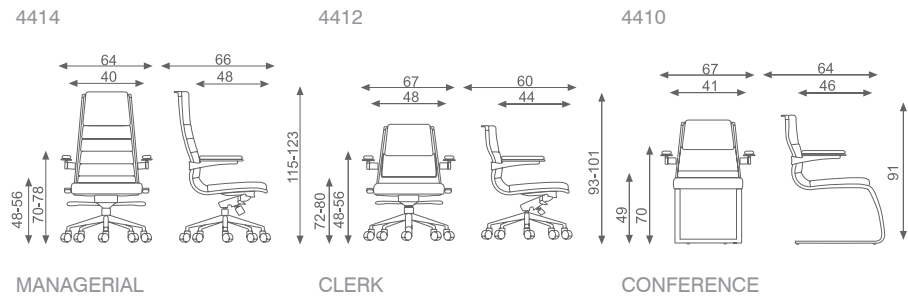
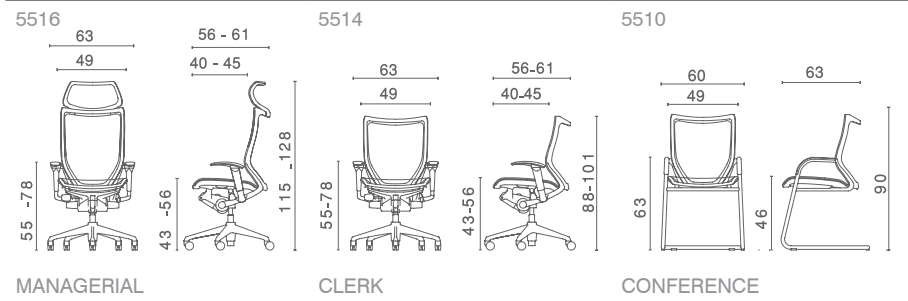

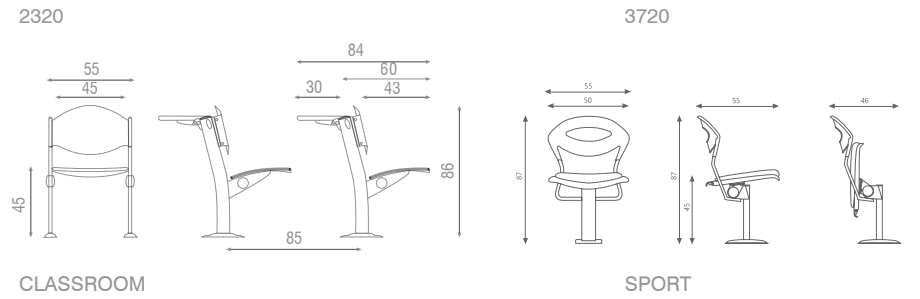
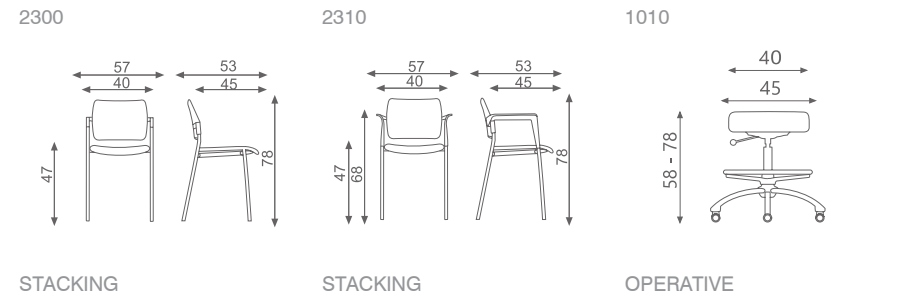
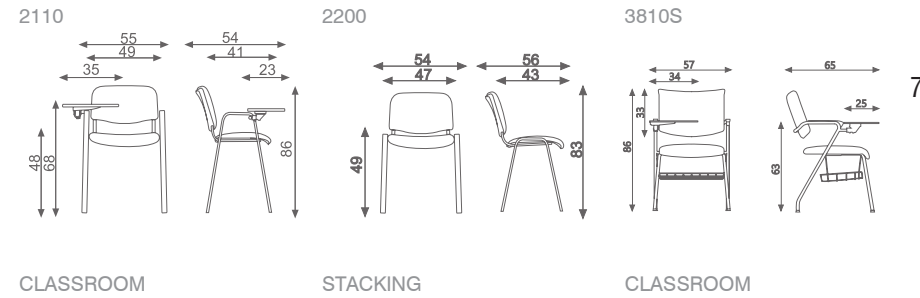
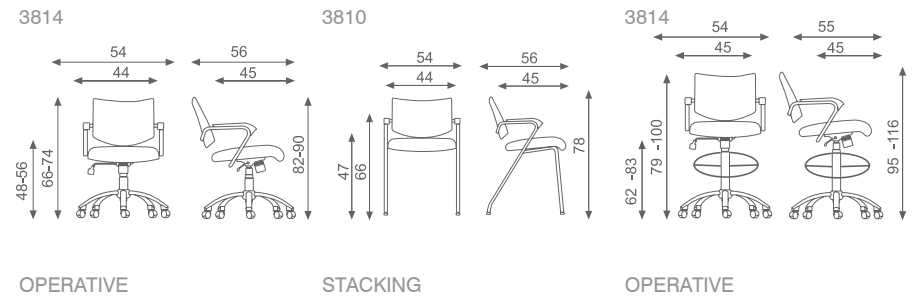
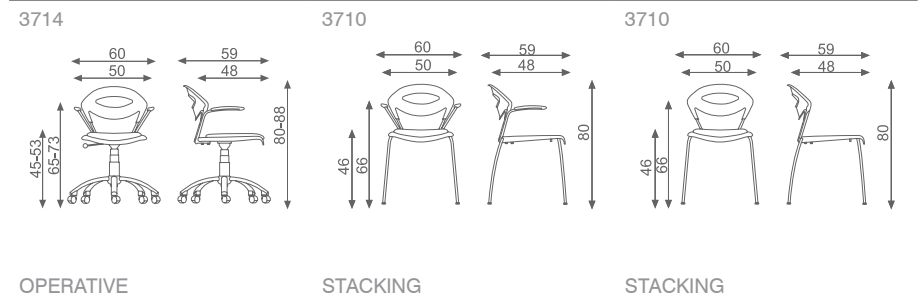
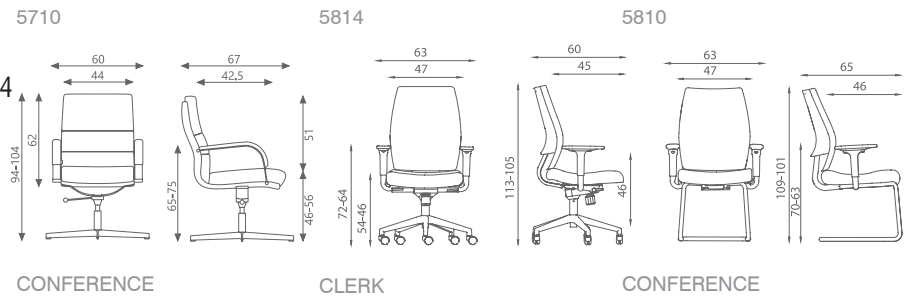
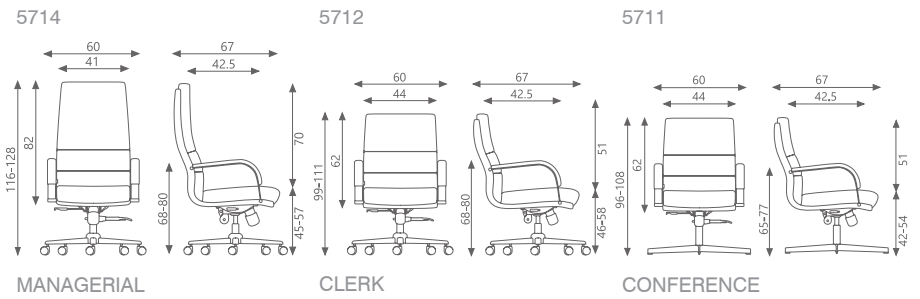
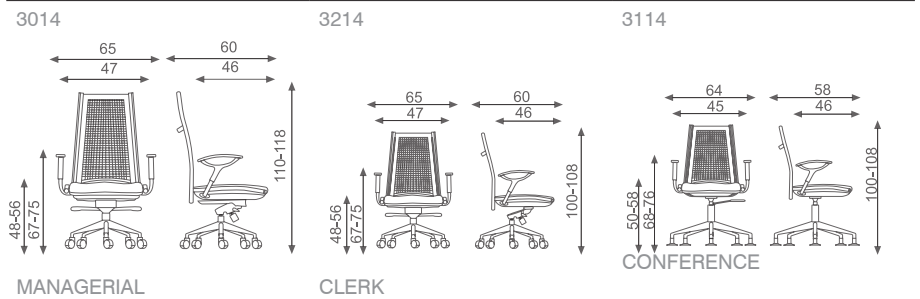

74

75

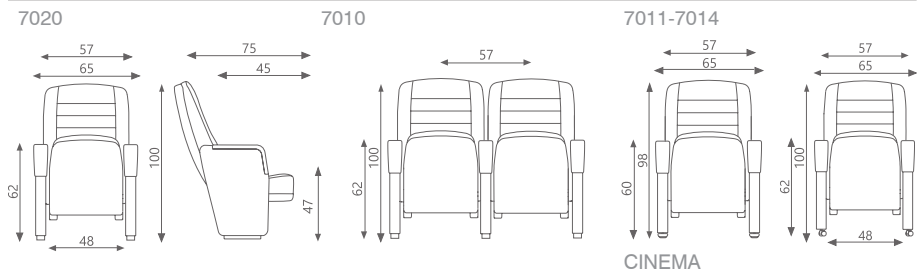

CINEMA

3910

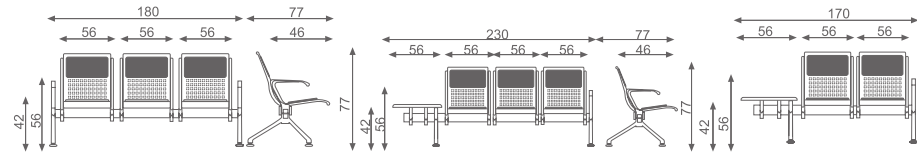

SEATING GROUP

3912

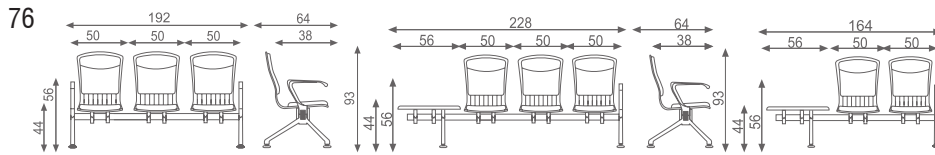

SEATING GROUP

4110

5110

5111

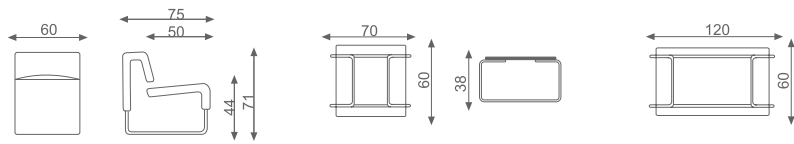

SEATING GROUP

TEA TABLE

TEA TABLE

4210

5210

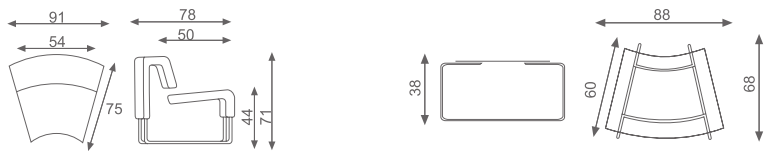

SEATING GROUP

TEA TABLE

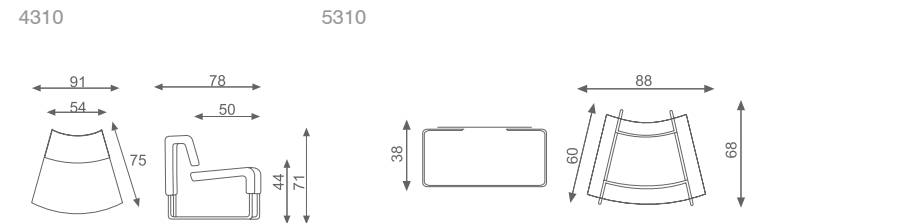

SEATING GROUP

TEA TABLE

4010

5010

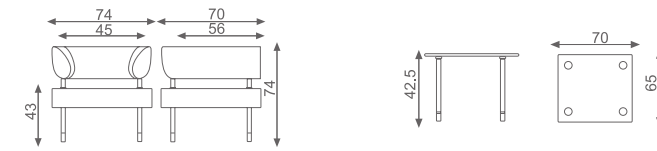

SEATING GROUP

TEA TABLE

4012

5012

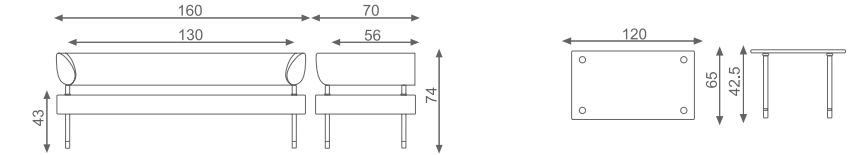

SEATING GROUP

TEA TABLE

4013

5019

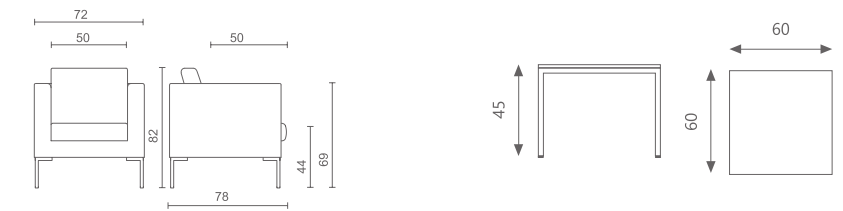

SEATING GROUP

TEA TABLE

4014

5020

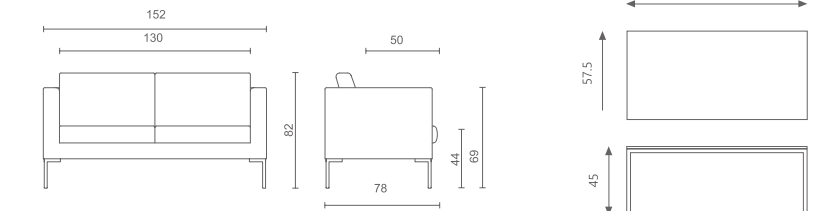

SEATING GROUP

TEA TABLE

4017

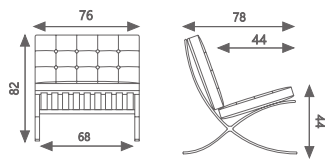

PUBLIC SEATING

5021

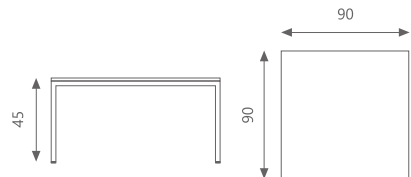

TEA TABLE

4018

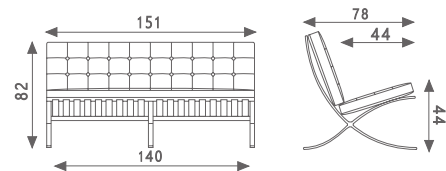

PUBLIC SEATING

5020

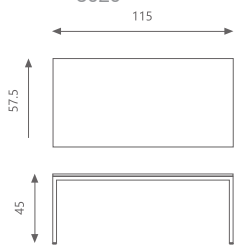

TEA TABLE

4019

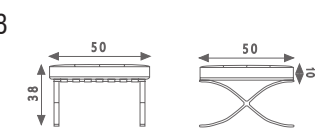

PUBLIC SEATING

4020

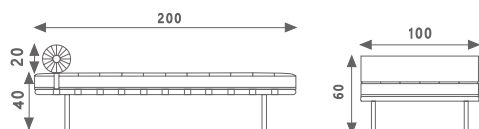

PUBLIC SEATING

4015

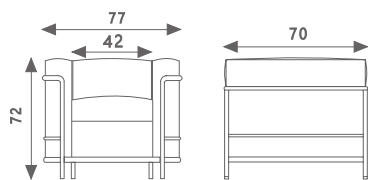

PUBLIC SEATING

4016

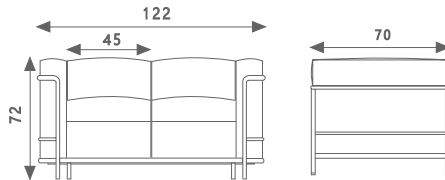

PUBLIC SEATING

1730

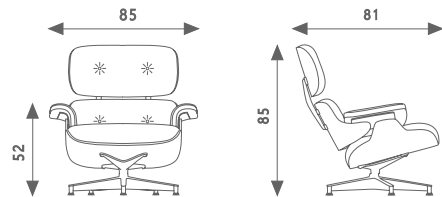

REST

1732

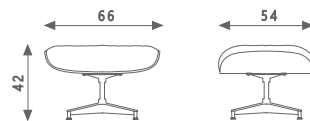

REST

3020

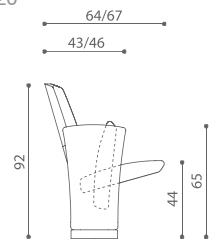

AMPHITHEATRE

3020

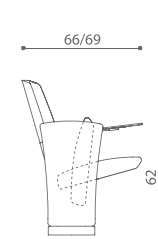

AMPHITHEATRE

3010

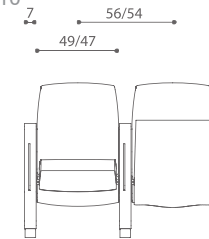

AMPHITHEATRE

2720

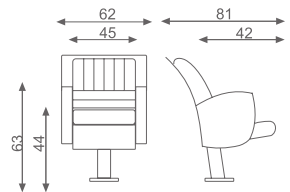

AMPHITHEATRE

2710

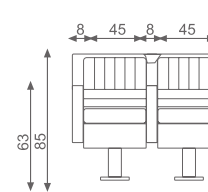

AMPHITHEATRE

2720

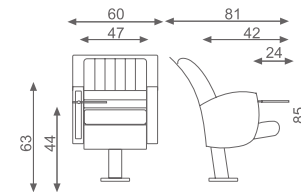

AMPHITHEATRE

2820

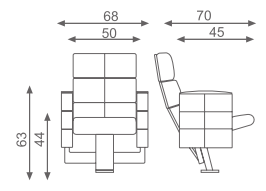

AMPHITHEATRE

2820

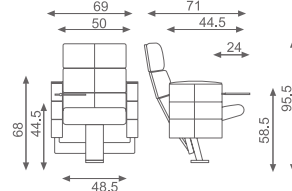

AMPHITHEATRE

2810

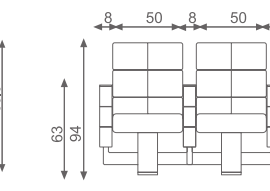

AMPHITHEATRE

78

79

2920

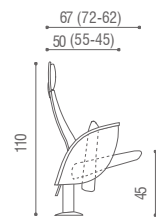

AMPHITHEATRE

2910

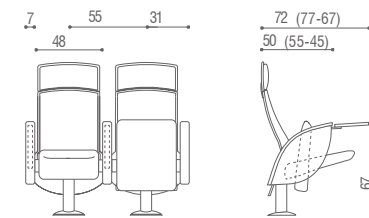

AMPHITHEATRE

3022

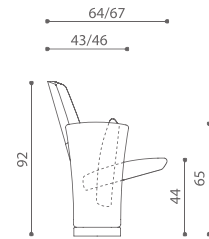

AMPHITHEATRE

3022

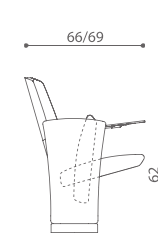

AMPHITHEATRE

3022

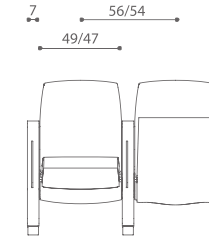

AMPHITHEATRE

5912

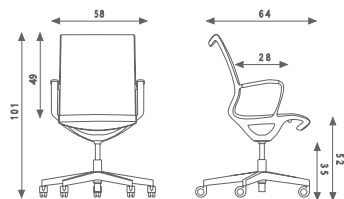

CLERK

5910

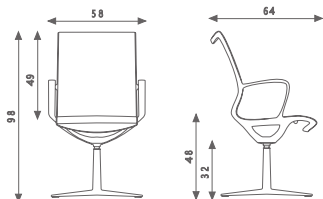

CONFERENCE

6014

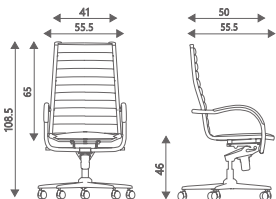

MANAGERIAL

6012

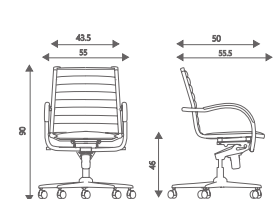

CLERK

6010

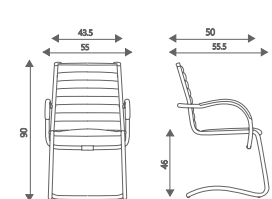

CONFERENCE

1740

80

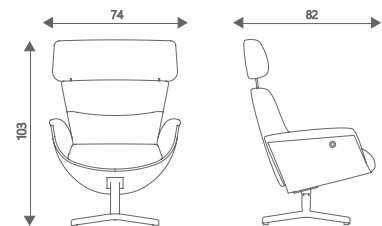

REST

1742

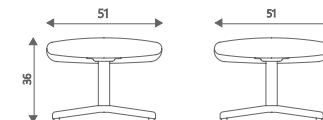

REST

1520

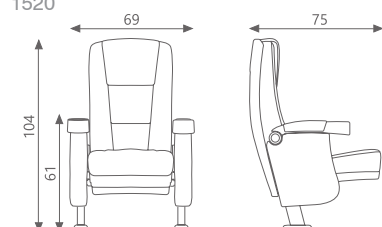

CINEMA

1734

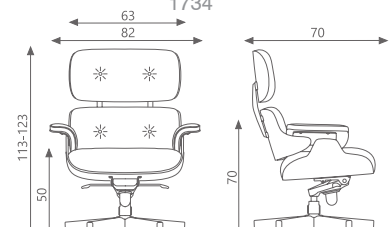

MANAGERIAL

1420

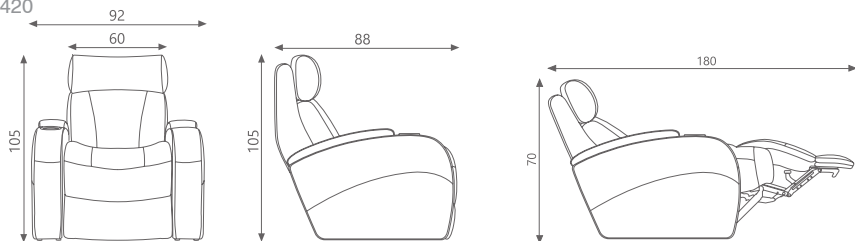

CINEMA

4030

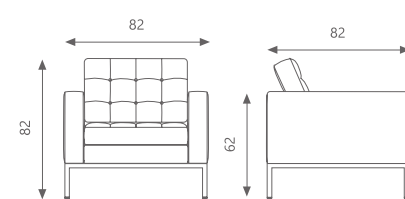

FLORENCE

4032

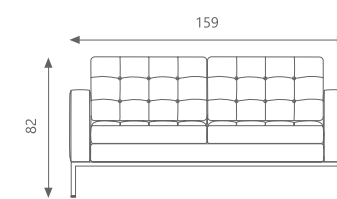

FLORENCE

4034

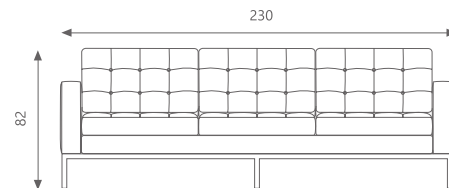

FLORENCE

4023

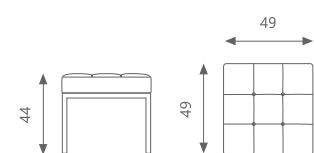

FLORENCE

4021

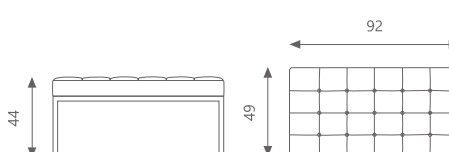

FLORENCE

4022

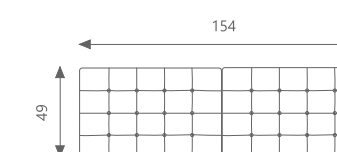

FLORENCE

5019

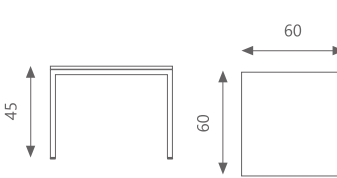

TEA TABLE

5021

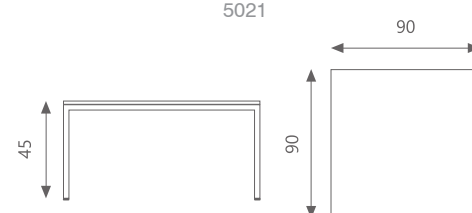

TEA TABLE

5020

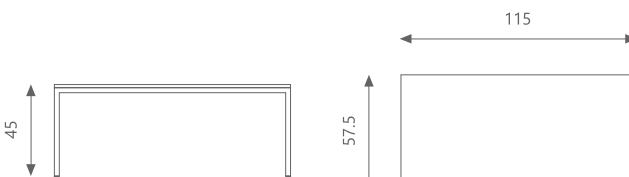

TEA TABLE

81

I prefer drawing to talking
Drawing is faster,
leaves less room
for lies



Le Corbusier



1928 Lc2 chair



Barcelona chair 1929



Ludwig Mies Van Der Rohe

A Chair is a very
difficult object
A skyscraper is
almost easier
That is why Chippendale
is famous



1952 Florence chair

Good design
is Good Business



Florence Knoll



Eames chair 1956



Charles and Ray Eames

The role of a
designer
is that of a very
good thoughtful
host anticipating
the need of
his guests

گروه صنعتی اروند از سال ۱۳۳۸ فعالیت خود را در زمینه تولید صندلی ها و مبلمان اداری و آمفی تئاتر آغاز نموده است و هم اکنون شصت و دومین سالگرد این تلاش مستمر در حال سپری شدن هست. در طول سالیان متمادی، این واحد صنعتی در زمینه تولید صندلی ها و مبلمان اداری و آمفی تئاتر، نقش چشم گیری ایفا نموده که دریافت نشان برترین تولید کننده مبلمان اداری در نمایشگاههای هوفکس اداری صندلی (Hofex Office Section) و همچنین کسب جایزه برترین کیفیت در حوزه اداری و آمفی تئاتر طی حدود ۲۰ سال، از سوی اتحادیه تولید کنندگان و صادر کنندگان مبلمان ایران، اثبات کننده این کوشش خستگی ناپذیر است.

تجهیز سالنهای محل برگزاری کنفرانس سران کشورهای اسلامی، مجلس شورای اسلامی و همچنین تجهیز سالن هایی از قبیل شرکت نفت و گاز و پتروشیمی، بیمارستان ها، مراکز آموزش عالی، فرودگاه ها، سالن های سینما و آمفی تئاتر و ... از افتخارات این مجموعه صنعتی در عرصه ملی محسوب می گردد. توسعه فضای تولیدی و انبارها در شهرک صنعتی جدید الاحداث بهسازی صنایع چوب ایران، استقرار سیستم های مدیریت، جذب نیروهای متخصص و ارتقای تکنولوژی تولید، از اقدامات قابل توجهی است که ورود به بازارهای جهانی را دست یافتنی تر از پیش می نماید. گروه صنعتی اروند بر آن است تا با استعانت از پروردگار متعال و بهره گیری از نیروهای متعهد، متخصص و دلسوز خود، نام ایران را در پهنه جهانی با واژه کیفیت قرین سازد.



